

HEGLA – Harp rack

F 50-16

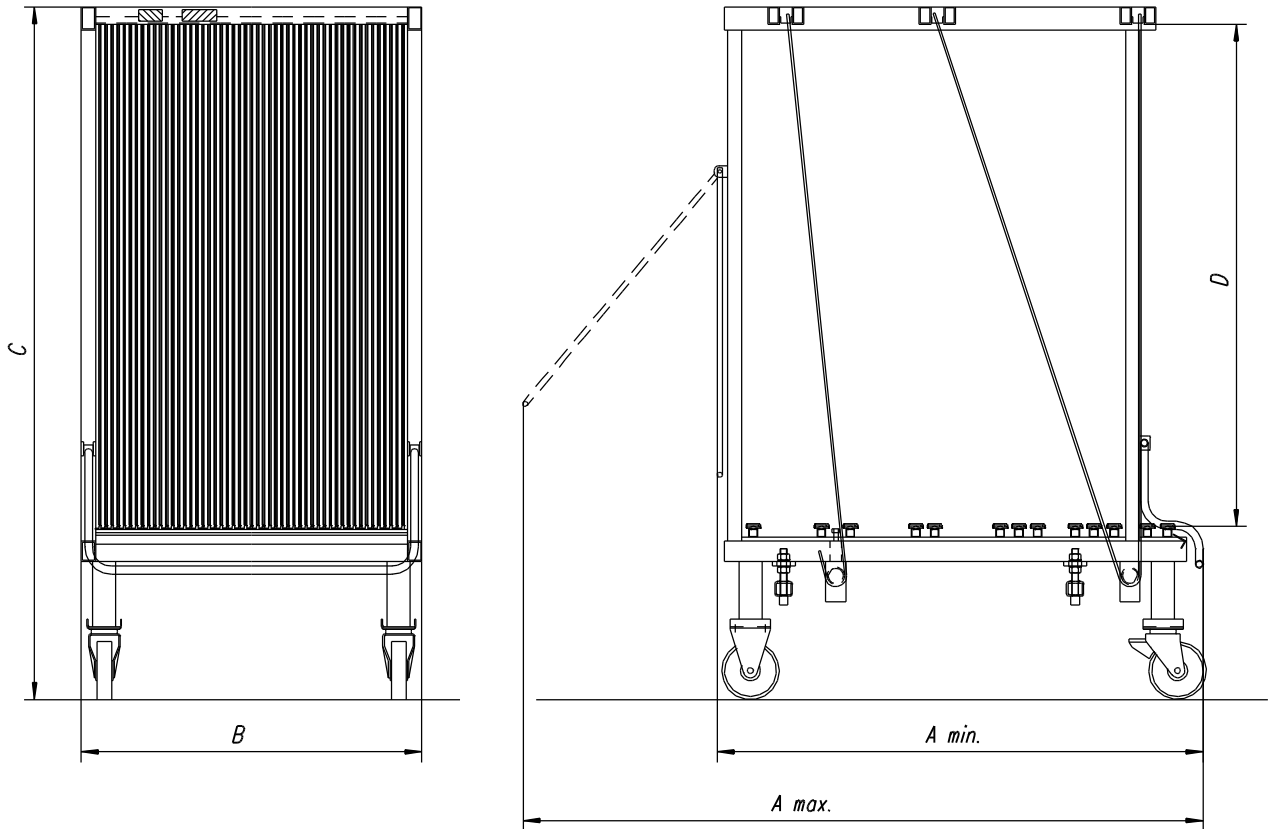

2 swivel rollers and 2 fixed rollers; made of polyamide; Ø 200 mm.
Optional as galvanized or painted version (ral colour 7040).

(A min.) Length	1685 mm	Number of racks	50 pieces
(A max.) Length	2355 mm		
(B) Width	1180 mm		
(C) Height	2398 mm		
(D) Loading height	1744 mm		

The products shown partly contain supplementary equipment being sold for additional charge. Only our written confirmation is legally binding.
Copyright © 2001 HEGLA, Beverungen. All rights reserved. Duplicating, also in extracts, only with written permission of HEGLA.

HEGLA
Industriestraße 21
D-37688 Beverungen
Phone: +49 (0) 52 73 / 9 05-0
Fax: +49 (0) 52 73 / 9 05-2 55
Email: info@hegla.de

HEGLA
Industriering 5
D-06712 Döschwitz
Phone: +49 (0) 3 44 25 / 5 01-0
Fax: +49 (0) 3 44 25 / 5 01-29
Email: info@hegla.de

HEGLA
Industriestraße 27
D-74589 Satteldorf
Phone: +49 (0) 79 51 / 94 35-0
Fax: +49 (0) 79 51 / 94 35-50
Email: info@hegla.de

HEGLA France
4, rue d'Otterswiller
F-67700 Saverne
Phone: +33 3 88 / 91 01 01
Fax: +33 3 88 / 91 05 05
Email: hegla.france@wanadoo.fr

HEGLA Corp.
1626-G Virginia Ave
College Park, GA 30337
Phone: +1 404 763 97 00
Fax: +1 404 763 09 01
Email: info@heglacorp.com

HEGLA Machinery (UK) Ltd.
Milton Keynes
GB-Buckinghamshire, MK8 0AJ
Phone: 0 19 08 / 26 19 33
Fax: 0 19 08 / 26 19 50
Email: steven.goble@hegla.co.uk